

CONCEPT LINE kera.round - Maßskizzen

WTM 8508

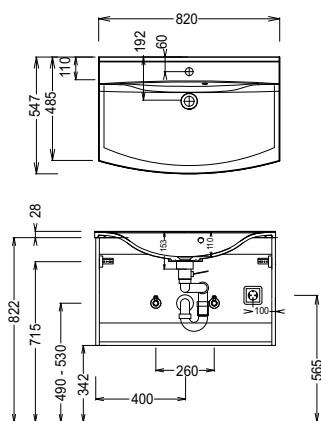

WTM 8510

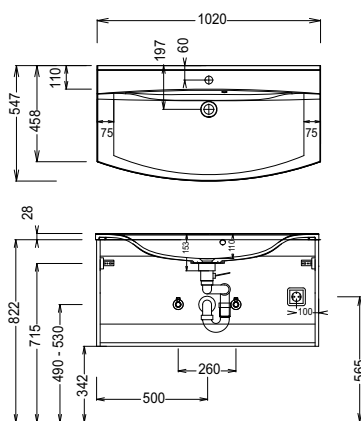

WTM 8520

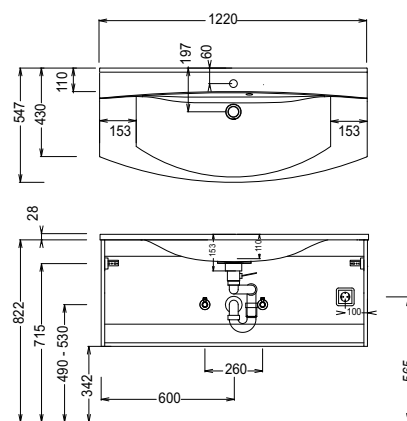

Elektroanschlüsse für Spiegelemente

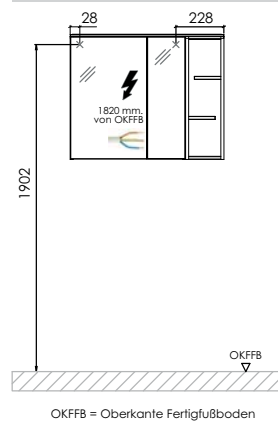

Toleranzen:
Die Maßtoleranzen (+/- 5mm) und Ebenheitstoleranzen (DIN 18202) unterliegen den üblichen materialspezifischen Toleranzen für Baustoffe, anlehnd an die DIN 18202.